

Chip Resistor Probe Cards

CHIP RESISTOR PROBE CARDS

Accuprobe has long been a leading supplier of probe cards used to facilitate the laser trimming of chip resistors. All major suppliers of laser trimming systems can be supported with probe card assemblies from Accuprobe.

SHRINKING SIZES

Chip resistors continue to shrink and challenge probe and interface capabilities where parallel row or column testing is required for enhanced production throughput. Larger substrates now being used for additional efficiency further extend the requirements of probe cards for this application.

Full Kelvin probing of the smaller 0603, 0402 and 0201 and equivalent metric size chip resistors can require high density multi-tier probe cards and commensurately sized interface cables and connectors. One common solution to the need for increased density is to use an integrated probe card and cable assembly similar to that shown at right.

Accuprobe stocks a wide range of printed circuit boards for a number of laser trimmers designed to test all standard resistor sizes and accuracy requirements as well as required stiffeners, cables and connectors. Complete chip resistor probe cards are assembled using these

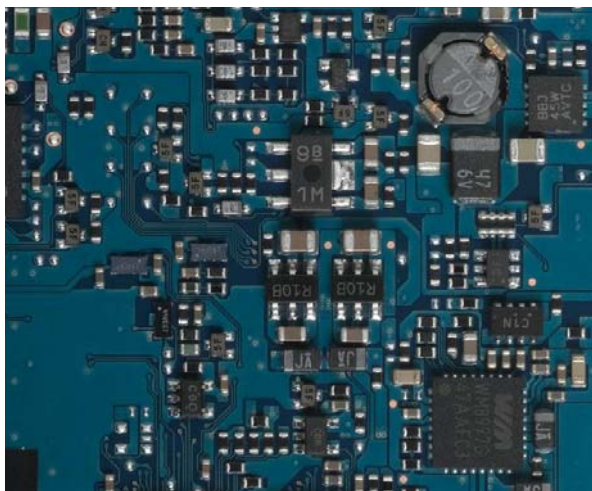

PCB with Chip Resistors

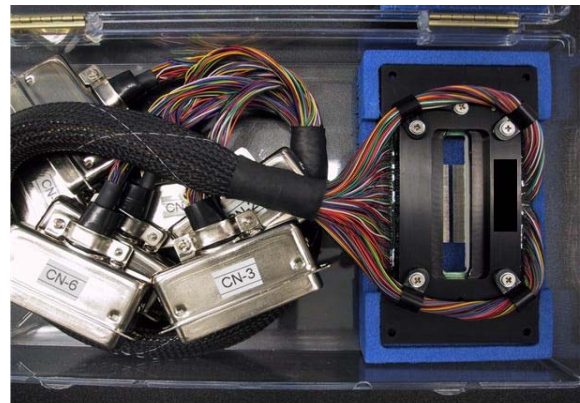

Integrated ChipR Probe Card Assembly

standard PCBs based on specific substrate, paste, metallization, values, and tolerance parameters.

SOLUTIONS AVAILABLE

A wide range of cantilever probe solutions for the laser trimming of chip resistors are available. Metal blade probe cards can provide resilient and cost effective approaches to larger substrates and are easily repaired locally in the event of wear or damage to the probe card. Z-adjustable probe cards are useful for smaller chip resistor networks, and the Kelvin variety of these probes can provide high accuracy and adjustability following wear.

Most smaller devices require an epoxy ring type probe card due to the tight pitch and high density associated with these parts. Full Kelvin probing down to the 0201 level demands multi-tier probe needles to reach pads with smaller areas than probe needle diameters. Accuprobe epoxy ring probe cards use custom ceramic parts for probe needle attachment, and proprietary epoxy adhesive with superior build, wear and performance characteristics.

REPAIR SERVICE

A significant advantage of a chip resistor probe card solution from Accuprobe is the ability to repair or rebuild the probe card at lower cost than the purchase of a new card. Regular Accuprobe customers benefit from the

Chip Resistor Probe Cards

fast, efficient and effective repair service where in the event that a card cannot be rebuilt, a new probe card is provided at no additional cost over the repair service charge.

DESIGN CONSIDERATIONS

Key considerations in any chip resistor probe card design are related to substrate size, resistor size, number of measurement channels available, as well as resistor value and tolerance. These factors drive the selection of the appropriate probe card solution as well as the probe needle size, type and related features. With internal probe needle processing capabilities, and a wide range of available platforms, Accuprobe has the capability of customizing the probe card design to provide the optimum performance for the chip resistor production environment.

Contact Accuprobe for all your chip resistor probe card needs.

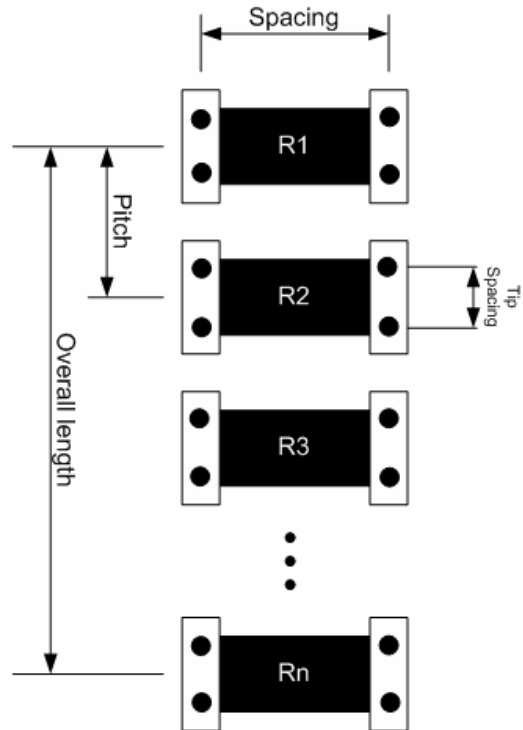

4T Kelvin ChipR Configuration

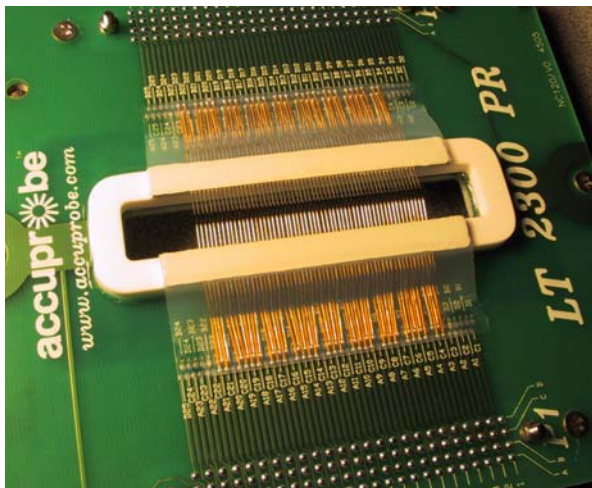

LT2300 Epoxy Ring Probe Card

BITA ELECTRONIQUE S.A.

618 BOITE POSTALE | LU-2016 LUXEMBOURG VILLE | www.bita.lu | info@bita.lu